

## 【装置全景と側面-1,2】

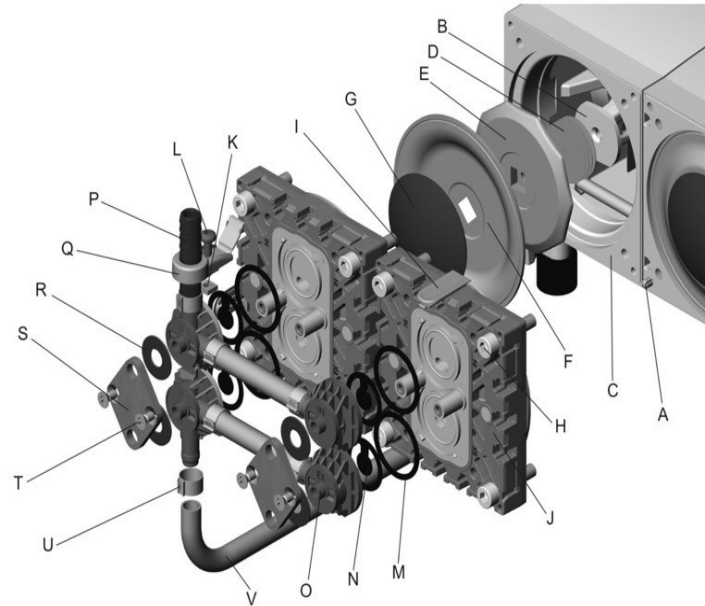

## 【参考 = Pump head parts】

View of the disassembled pump head parts  
(fig.: MD 4C NT)



- |   |  |
|---|--|
| A: Head alignment pin / mark                      | L: Fillister head screw                  |
| B: Connecting rod                                 | M: O-ring                                |
| C: Housing  | N: Valve                                 |
| D: Washer   | O: Valve head                            |
| E: Diaphragm support disc                         | P: Hose nozzle                           |
| F: Diaphragm                                      | Q: Connection fastener with hinged cover |
| G: Diaphragm clamping disc with square head screw | R: Disc spring                           |
| H: Allen screw                                    | S: Clamping bracket                      |
| I: Cap  | T: Countersunk screw                     |
| J: Head cover                                     | U: Hose clip                             |
| K: Square nut                                     | V: Connection tube                       |

This labeling is used throughout the following pages.

## 【装置前背面と上面】

